

Illumination Unit NF-3m-H2

NF-3m-H2 (former NF-3mEC) is a unit of NF-3m designed for indoor helicopters powered by batteries 2S or 3S LiPol typically EasyCopter. It is used to supply color ultra bright LEDs with rated currents up to 20 mA. It has six lights: one green position light **P1**, one red position light **P2**, two flashing lights **F1** and **F2** (red or white) and two white landing lights **L1** and **L2**.

Both outputs of the anti-collision lights flash every one second. One of 8 combinations of flashes can be selected by blue jumpers (**1, 2, 4**). The sum of numbers of the connected jumpers represents the number of the selected combination (see

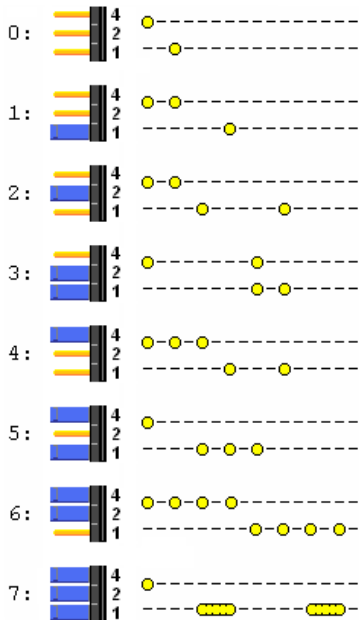

Fig. 1).

The unit is connected to the accumulator in parallel with the circuits of the model. The red wire of the unit must be connected to the positive pole of the accumulator, the brown wire to the negative pole. Be careful, the reversal of polarity can destruct the unit.

The total average current consumption by all lights on is between 12 mA from 5V power supply to 32mA from 12V power supply. During 10 minutes of fly the light circuits burn only a little bit more than 1 % of capacity of a 700 mAh accumulator.

When performing the installation with a night fly model, you have to keep certain rules to ensure the model to be visible in all positions so that flying at the night is secure. Ultra bright LEDs are directional light sources compared to light bulbs. They light with angles of 15, 23, 30, rarely 70°. The directional characteristics of diodes should be adjusted so that they are visible from large angles. The easiest way to do that is by roughening them with emery paper. It is also possible to drop some adhesive from a fuse pistol on the diode, or combine these two methods.

Fig. 1

Installation procedure

The typical unit connection is shown by the scheme on Fig. 2. Color as well as position of diodes in a specific model may vary. Remember that the conventional placement of position lights is: green on the right and red on the left (in the direction of flight). For the best intensity of LEDs it is recommended to place only one LED per output and connect them as is shown in the image below.

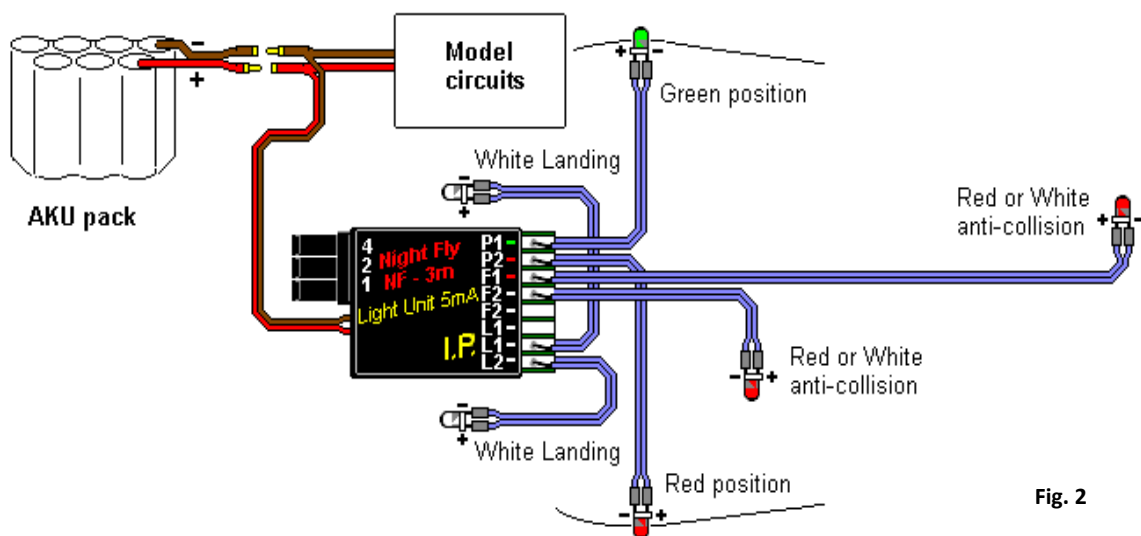

Fig. 2

Arrange a conduction from the diodes to the NF-3M-H2 unit. The wires should not create a surface loops and both wires should be drawn as close as possible to each other. The ideal solution is to use a thin two-core wire, or a pair of enameled wires that can convert to a twisted pair cable. It is not recommended to place the conductors in close proximity to the receiver or in parallel with the antenna receiver. That could affect reception of the signal. Whether you

use the enamel cable or any pair-cable, it is necessary to prepare cables with a sufficient reserve. A few centimeters in excess can be hidden but just one missing centimeter will cause you trouble. The diodes pins can be shorten, but at least 5 mm must stay. Than remove the insulation from 5 mm of the enamel cable and tin the cable than the diode. This will shorten time needed for soldering them together. If you plane to put thermo-shrinkable insulation tube over the connection, prepare 9 mm-long pieces of insulation.

They shall be pulled on the wire beforehand as far as possible from the intended soldered connection – if not, they could shrink in a wrong place. After soldering in both stems and cooling pull the insulation on the connection and heat it gently from all sides with the solder so that it would shrink (you need to try it). It is recommended to heat at a place behind the tip where the solder is clean. Thus the insulation will not be contaminated with remnants of tin and resin.

You may check the function of the unit by connecting it to the accumulator and by putting diodes on the unit's contacts. In that way it is possible to check the diode's color as well. When connecting the diodes to the unit one must observe the polarity.

ATTENTION: Do not try to test the diodes with direct connection to the power supply accumulator; without using a compensation series resistance you would destroy the diodes by that.

Soldering of LEDs: The diodes pins can be shorten, but it is recommended for them to be 5-7 mm as they are also designed to carry off the heat when soldering and during the operation. Having the polarity recognizing on mind it is recommended to leave the positive pole longer when shortening. It is necessary to prepare cables with a sufficient reserve. A few centimeters in excess can be hidden but just one missing centimeter may cause bit trouble. Before connecting the diodes, remove the insulation up to about 5 mm of the enamel cable and tin the cable and the diode. This will shorten time needed for soldering. If you are going to put insulation tube over the connection, prepare 9 mm-long pieces of insulation and pull them on the wire beforehand.

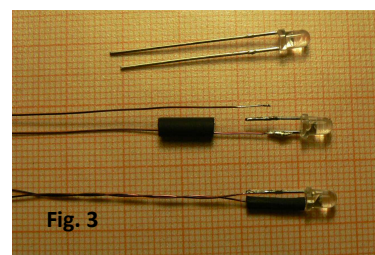

Fig. 3

The picture shows a situation in which the unit has been soldered with wires and from two diodes. In indoor helicopters the best place for the unit installation is in the front part of cabin. At the same time the unit is connected to the battery. If the battery is equipped with a connector for cells trimming, it is very convenient to use it for lighting. In that case you do not have to modify existing electro-installation and you can turn-on illumination for decorative purposes without the need to switch-on the electronics. In such cases it is advisable to lead the two connectors on the accessible place, preferably a hole for the accumulator behind the cab.

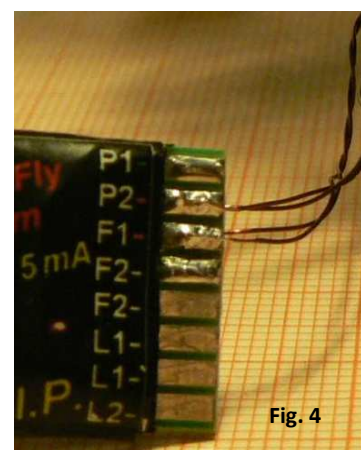
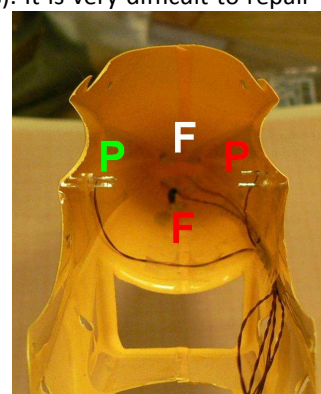

Fig. 4

ATTENTION : When soldering, the unit must be safely removed and disconnected from the power source otherwise you may damage the unit. We recommend to connect LEDs into the unit one by one. The unit always turn on and check if the LED is active (illuminates). It is very difficult to repair when all LEDs and wires are connected.

The manufacturer is not liable for damages caused by the operation of the unit beyond the technical parameters and the above recommendations. Instructions for the implementation of socket adapters, cabling and more information about diodes can be found on the website.



Technical parameters NF-3m-H2

	min	typ.	max.
Operational Voltage [V]:	4.5	5.0	12.5
Consumption (5 V) [mA]:		12	
Consumption (12 V) [mA]:		32	
Circuits F (freqv. 1 Hz):		pulses 66 ms	
Temperature:		0 – 70 °C	
Dimenstions [mm]:		33 x 18 x 5	
Weight [g]:		4.1	

Production:

Ivan Pavelka
K Roztokům 65
165 00 Praha 6 – Suchdol
Czech Republic

tel:+420 605 404 499
E-mail: info@nightfly.cz
www.nightfly.cz

