

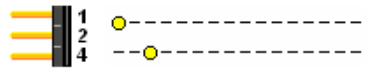

Illumination unit NF-5XL

Description : **NF-5 XL** unit is designed for illumination of big models with wingspan two meters and more. It is used to power color ultra bright LEDs (Light-Emitting Diode) with the nominal current of 350 or 700mA, flash upto 1000mA (version **NF-5XL** up to 1500 mA). The unit contains eight independent current-powered outputs. Two outputs are for position lights **P1** and **P2**, three outputs are designed to power the anti-collision flashing lights (**F1**, **F2** and **F3**) and three outputs power the landing lights (**L1**, **L2** and **L3**). Switching on of the second landing light output is delayed by one second against the first landing light output. That produces an effect of phased switching by the pilot.

<p>0: </p> <p>1: </p> <p>2: </p> <p>3: </p> <p>4: </p> <p>5: </p> <p>6: </p> <p>7: </p>	<p>The unit offers eight different flashing combinations (0 -7) with one second period for F1 and F2 outputs. One of those combinations can be selected by blue jumpers 1, 2, 4. The sum of numbers of the connected couplers represents the number of the selected combination.</p> <p>The F3 output has an independent time base so its flashes drift slowly against flashes F1 and F2. This makes more realistic impression. The F3 jumper contacts make possible to set the number of flashes of the anti-collision light F3. With jumper on position "2x" or "3x" the unit produces two or three flash pulses per second. Without jumper, the light makes one pulse.</p> <p>Unit is in non-controlled mode if the Rx cable is not connected to the receiver. In this case the lights start work when the unit is connected to the accumulator and the "3P" jumper can be used to switch manually the landing lights off. With disconnected jumper landing lights are switch on, with connecting jumper 3P they will be switch off.</p>
--	---

Plugging the connector Rx into a free channel on the receiver you get the option to turn on the lights during the flight. Red jumper "**3P**" mode selects the mode to control the lights. Disconnected jumper sets the mode of the two-positional control **2P**, inserted elects three-positional control **3P**.

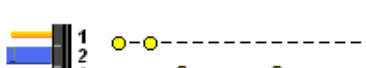
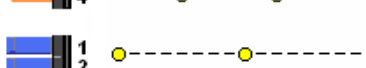
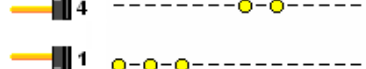
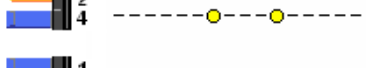
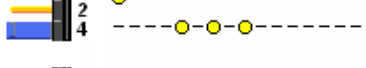
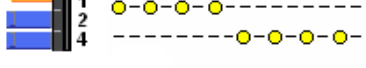
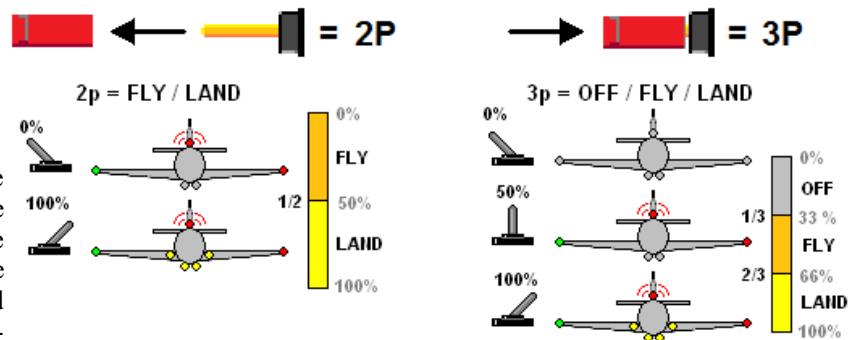

In **2P** mode position and anti-collision lights are on continuously and landing lights are controlled from the transmitter. The **3P** mode is the standard range of servo divided into thirds. In the first lights are switched off, in the second position lights and anti-collision lights are switched on, in the third all the lights are switched on.

Anti-collision and landing lights automatically begin to flash when the plane is unable to receive a signal from the remote controller. The receiver circuit and the light circuits are electrically separated by an opto-coupler. Unit is compatible with Graupner or Hitec-type connectors.

The outputs maintain the nominal current in the wide range of voltage from (4,8V) 6V to 14V without the need to connect compensating resistance series in the circuit. The stabilization starts working from 5,0V, therefore it is possible to connect the unit to a NiCd or NiMH batteries from 4 up to 10 cells or Li-Pol from 2 up to 3 cells. As the number of the cells of the powering accumulator increases, so does the number of diodes that can be connected (serially) on each output. Using seven-cell-accumulator, 2 green or white diodes or 3 red or yellow diodes can be connected into one output. It is only necessary that the sum of voltages of diodes plus 1,8V (for output circuit functionality) is below the voltage of accumulator, otherwise the luminosity of LEDs falls down. The typical working voltage for red and yellow LEDs is 1,8 to 2V. For white and green it is from 3,0 to 3,3V. The colors of diodes in one circuit can differ. The diodes are powered from the positive pole of accumulator against the common negative pole.

Installation procedure: The typical connections are shown by the scheme below. Number, color as well as position of diodes in a specific model may vary. By models with on-board power supply of 6V and less there will probably not be possible to connect more than one diode to each output if you do not use a separate supply with a higher voltage for the light supply.

You may check function of the unit before installation by connecting it to the accumulator and touching light circuit outputs with diodes. In this way it is also possible to check the diode's color as well. If you keep the input voltage, there is neither danger for the unit nor for the diodes. Do not test the diodes by connecting them directly to the accumulator.

Without a compensating resistance you would destroy the diodes. When connecting the diodes you have to observe the polarity. The positive pole of 20 mA LEDs has a longer outlet (a) and the negative pole has a trimmed edge (b) and usually extends inside the body (c) to hold the chip. The LEDs with 120mA, 350mA and more can have the different construction and markings. (See. Annex on the last page).

The NF-5XL unit allows to select by jumper on each output between the two values of output current, eg. 120 or 350 or 350 mA or 700 mA Lower of the two values is selected by disconnected jumper. Inserted jumper switches the output to a higher value. The current setting is marked by red and blue points on the sticker. Red points represent lower current values (outputs without jumpers). Blue points show higher current values (outputs with jumpers). In the following picture the positional and landing lights without jumpers have current 120mA with jumper 350. Flash lights without jumpers 350, 700mA with jumper.

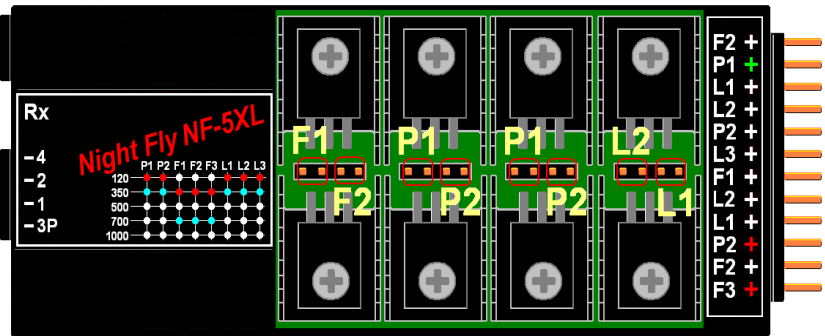

Units NF-5XF, which allows you to set current 700mA and higher, have fan on the cooler for active cooling. To change a jumper setting, the fan should be unscrewed.

DO NOT CONNECT a diode to the output with the current bigger than the nominal current of the diode. You would destroy the diode. Some types of 120 mA LEDs can work at 350mA in flashing mode. They are designed to support a short time overloading. This is exception. Newer test it for position or landing lights. **DO NOT TEST** the diodes by connecting them directly to the accumulator. Without a compensating resistance you would destroy the diodes.

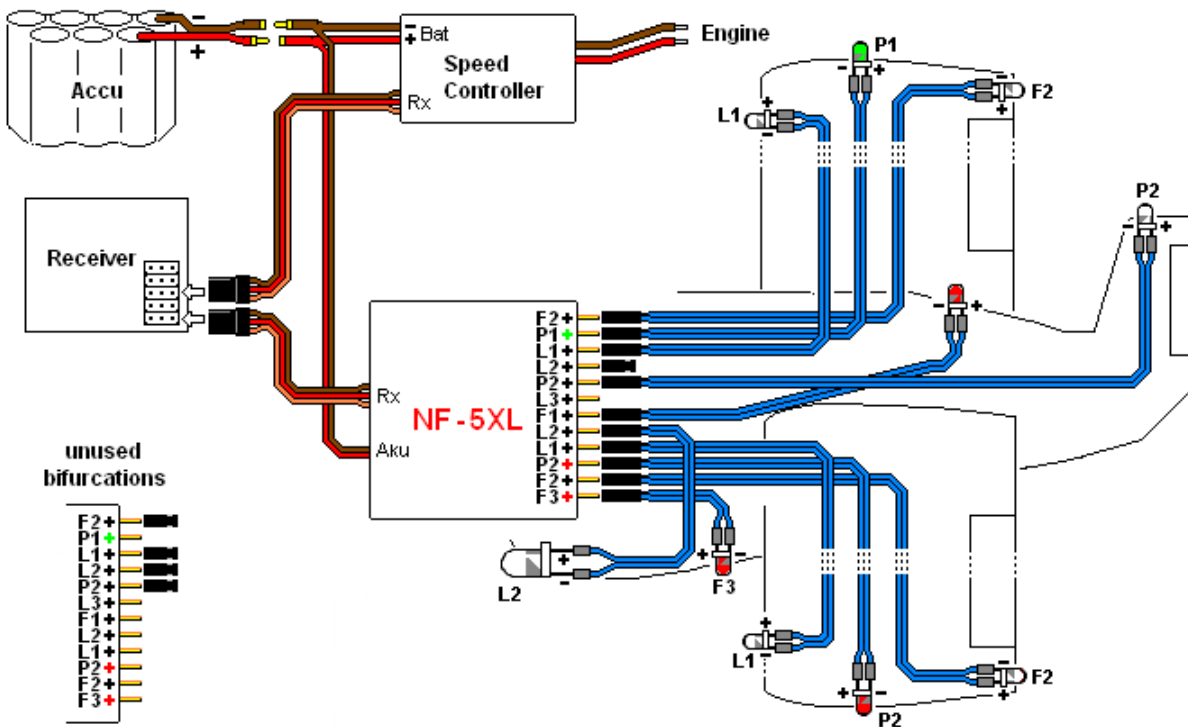

A short-term short circuit at a unit output does not harm the circuit thanks to the current outlets. The circuit regulates the current by burning the voltage difference between the supply voltage and the necessary voltage for diodes in the transistor. The worst condition for the unit is the case when the circuit is supplied by high voltage and short circuit at the output occurs. In that moment, the entire power (the passing current x power supply voltage) changes to heat in the transistor. Transistors can not burn the entire long-term power supply. Their coolers are counted with burning power until about 2W. For bigger power is required larger cooler, which represents more weight, or greater risk of burn. It is thus a compromise choice between weight and power reserve.

Before starting with the installation, make an approximate calculation of the voltage output summa. Accumulator voltage - the sum of the voltage of diodes in the circuit = voltage at the transistor. If you come out the voltage x current set up by circuit is higher, it's necessary to think about bigger cooling or a smaller supply voltage. Just for guidance, you can connect the unit in your expected configuration and check the temperature of coolers by touching them occasionally; holding it for longer you would carry the heat off to your fingers. If you can still keep your fingers on the cooler after two

or three minutes, everything is ok. Be careful; diodes, especially with current 350mA heat up. It is not recommended to close them in polystyrene as they need some air circulation around. Superheating causes loss of brightness and subsequent damage of the diode.

Add up also the currents of the individual circuits plus stand-by current of the unit ($I_0 = 20\text{mA}$) and determine what accumulator capacity the lights will burden. Currents of flash circuits are not to be included in full but take only the ratio of the number of pulses in a period divided by 16. For example: for three pulses/sec it is $IF1 = 3/16 * 150\text{mA} = 28\text{mA}$. Also landing lights calculate by the ratio, depending on whether they illuminate the airplane during the whole flight or just at taxiing and landing.

Diverging : Output pairs is embedded in NF-5 unit to simplify installation of pair lights (especially on wings). There are **F2, L1, L2** and **P2** pairs of output connectors. If you decide to use only one output of a pair outputs, the other one of this pair must be bridged by a jumper (see the picture above). Other variants of bifurcations are presented below.

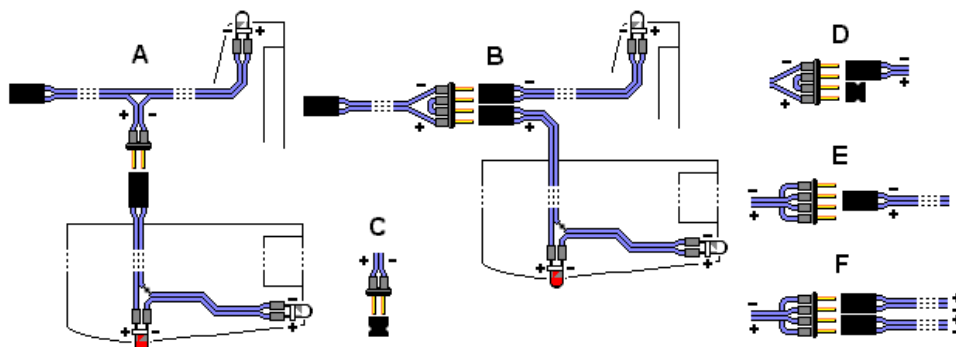

In the case that you realize the bifurcation and then you decide not to use one branch, you have to the unused output of the jumper in the variations A and B isolate by jumper as shown on picture C or D. If you don't do it, the second branch would not shine. From this point of view the jumper on figures E and F appears the best. There is shown that you can connect one or two branches without need to use the jumper. Just keep in mind that in case of connecting two branches (Fig.F), the polarity of the jumper's output reverses compared with the involvement of one branch. (Fig.E).

For flying at night it is useful to keep certain rules to make sure the model is visible in all positions and that night flying is safe. Unlike bulbs, ultra bright LEDs are narrow directional light sources. They light with angles 15, 23, and 30, rarely 70° and 120°. The directional characteristics of diodes should be adjusted so that they are visible from large angles. The easiest way to do that is by roughening them with emery paper. It is also possible to drop some adhesive from a fuse pistol on the diode, or combine these two methods. If the wing has a thick profile it is preferred to put two diodes there, one on the leading edge and the second on the trailing edge of the wing.

Making the cabling: Whether you use any pair-cable or enamel, it is necessary to prepare cables with a sufficient reserve. A few centimeters in excess can be hidden but just one missing centimeter will cause you trouble.

Before connecting the diodes remove the insulation from 5mm of the cable and tin the diode and the cable. This will shorten time needed for soldering. If you plan to put thermo-shrinkable insulation tube over the connection, prepare 9mm-long pieces of insulation. They shall be pulled on the wire beforehand as far as possible from the intended soldered connection – if not, they could shrink in a wrong place. After soldering in both stems and cooling pull the insulation on the connection and heat it gently from all sides with the solder so that it would shrink (you need to try it). It is recommended to heat at a place behind the tip where the solder is clean. Thus the insulation will not be contaminated with remnants of tin and resin.

After fixing the diodes and checking the length of cables we must connect the connectors. They could be crimped without soldering but if you have the solder in hand and do not have the tools for crimping, I recommend soldering. Divide the couple of wires for about 20-25mm and remove the insulation of 4mm of wire and tin it. If you are not fast, the insulation will recede a little more. Shorten the uninsulated tinned wires to 2-3mm. Break off two sockets and gently clamp them in parallel in a clamp at a distance at which they will be in the connector. The included fork adaptor can be used for clamping as well. Ideally you fix the sockets and the wire on a surface area. Drop a little tin in the middle part of the socket, not too much. The thin tube tin is easier to dose. Put the wire in the farther socket and heat it so that the tin connects. Then repeat it with the closer socket. See to it that the wire and the socket would be in line. If your hand slips, you can heat the wire again and when it gets released, fix it. Keep eye on the solder temperature, you might lose the insulation. Keep the same polarity with all the cables, it is aesthetical. If you e.g. solder the diodes' positive pole on the farther socket, the locks of all connectors will be oriented upwards.

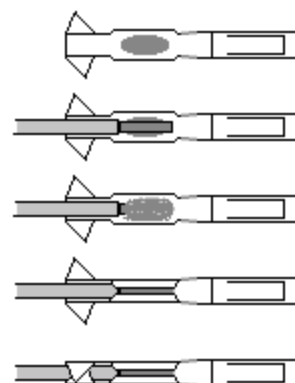

Bend the borders of the channels round with flat pliers. Then bend the plates around the insulation and finally put the sockets in the connector so that the locks would lock on. If there is resistance, gently try to lift the lock on the connector with a tip. Not too much, otherwise it will stay open forever. Lean the tip at the edge of the socket and gently move it forward. You probably used too much tin or bent the borders too little.

Tests after installation and interference test:

The unit can be fixed by screw of the heatsinks clamps in the way you unscrew the nuts and replace them by distance columns that are part of the accessories. Column with inside thread or column with external thread can be used as you need. The distance columns can be screwed or glued to the plywood into pre-grinded hole. The space around the unit should be considered too as to the air circulation and especially the access to the connectors and jumpers if your model is demountable one. It is not recommended to close the unit in polystyrene as they need some air circulation around.

You have also to keep certain rules to prevent interference with receiver and antenna. When installing lights the length of wires inside a model will increase many times. The wires should not form surface loops. Both wires should go as close as possible to each other to do not produce interference. The twisted pair gives the best result. However, they should not run in parallel with the antenna. They could affect its sensitivity. Therefore we recommend a spatial separation of the lights circuit, the power circuit accumulator-regulator-engine and also the receiver's antenna.

At today's currents running through engines, an insufficiently shielded engine is a source of interference that radiates into a space of approx. 30cm of supply cables. If lights are connected to the same source, up to 5m of cables may be added. That is up to ten-fold growth of length of vires that will not improve the situation in the model. After installation it is better to check the model's behavior on the ground first. If an interference occurs, it is necessary to check the installation of the power part and it is suitable to connect a small anti-interference member to reduce the degree of penetration of interference in the light circuits. For big airplanes we recommend a separate power supply accumulator for light system.

Also it's necessary to verify thermal conditions on unit's heatsinks and on position and landing lights, especially on those with current 350 mA and more. Test it as described in previous text.

Appendix : LED Polarity Marks

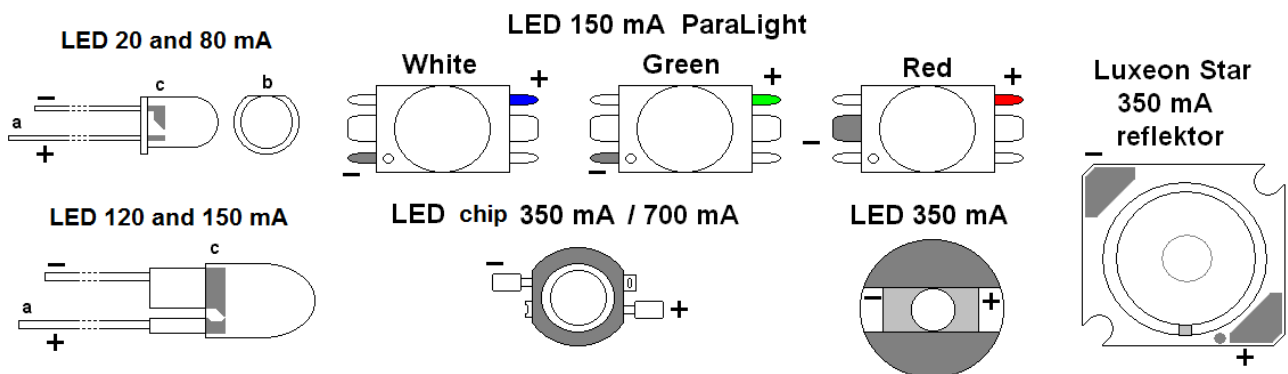

For 20 and 80 mA diodes the positive pole has a longer outlet (a) and the negative pole has a trimmed edge (b) and usually extends inside the body (c) to hold the chip.

ParaLight type LEDs 150mA have a "dot mark" near the negative pole (cathode). The positive pole is often in the opposite corner. ATTENTION : Red LEDs have cathode in the middle contact.

The Luxeon chips have a small embossed symbol of minus "-" at the opposite end of the minus pole (cathode). Chips on cooler, usually, have printed symbols "+" and "-". Luxeon Star Reflectors have a point printed nearby positive pole.

Have nice flying.

Illumination unit NF-5XL

Technical parameters:	min.	typ.	max.
Input Voltage:	5V	9V	16V
Consumption (unit):	16 mA	20 mA	24 mA
Current per output:	120, 350 mA		
Flash (freq. 1 Hz):	66ms pulses		
Temperature:	0 - 70°C		
Dimensions:	125 x 43 x 20 mm		
Weight:	59,5g	60,0g	60,5g

Production:
Ivan Pavelka
K Roztokům 65
165 00 Praha 6 - Suchbátov
Czech Republic

fax.: +420 220 921 744
tel: +420 605 404 499
i.pavelka@volny.cz
www.nightfly.cz