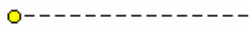
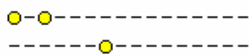

Illumination Unit Night Fly NF-3X-150

Description: **NF-3 X** is a unit designed for illumination of models with spread up to 1.7 metres for flying at night. It is used to power colour ultra bright LEDs (Light-Emitting Diode) It contains six independent current-powered outputs. Five outputs are powered with the nominal current of 20 mA. Two outputs are for position lights (**P1**, **P2**), two independently flashing ones for the anti-collision flash lights (**F1**, **F2**), and one output for the landing lights (**L1**). The sixth output (**L2**) is designed to power the landing headlight of 80, 150 or 350 mA (according to the respective type). Operation of the output L2 is one second delayed to the output L1. That produces an effect of phased switching by the pilot

0: 

The unit offers eight different flashing combinations (0 -7) with one second period for **F1** and **F2** outputs. See the diagram on the left side. One of those combinations can be selected by couplers (jumpers) **1**, **2**, **4**. The sum of numbers of the connected couplers represents the number of the selected combination.

1: 

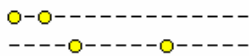
2: 

The unit can be used as controlled or non-controlled by pilot. If controlled by pilot, the jumper "**3p**" allows you to select between 2-positions (Fly/Landing) or 3-positions (Off/Fly/Landing) control by the remote controller. With a 2-positions control the position and anti-collision lights start work when the unit is connected to the accumulator. However, the landing lights can be switched on and off by pilot. In the 3-positions control system, all lights are off in the off-position. In the fly-position the position and anti-collision lights are on and in the landing-position, all lights are on.

3: 

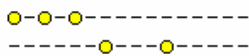
4: 

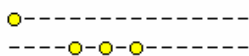
5: 

Unit is in non-controlled mode if the Rx cable is not connected to the receiver. In this case the lights start work when the unit is connected to the accumulator and the "3p" jumper can be used to switch manually the landing lights off.

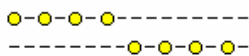
6: 

Anti-collision and landing lights automatically begin to flash when the plane is unable to receive a signal from the remote controller. The receiver circuit and the light circuits are electrically separated by an opto-coupler. Unit is compatible with Graupner or Hitec-type connectors.

7: 

The outputs maintain the nominal current in the wide range of voltage from 6V* to 14V without the need to connect compensating resistance series in the circuit. The stabilization starts working from 4.5V, therefore it is possible to connect the unit with the used NiCd or NiMH batteries with 5 up to 10 cells or Li-Pol from 2 up to 3 cells. As the number of the cells of the powering accumulator increases, so does the number of diodes that can be connected (serially) in one circuit.

NOTE *: The unit contains protection against reversal polarity connection to a power supply. It can be ordered also without this protection circuit, as so called "low voltage version" (4,8V - 6V) . In this case the unit works also in connection with 4-cells NiCd or NiMh accumulator but the reversal on input voltage can destroy it. So be carefull and use a connector with protection lock when working with "low voltage version".

Installation procedure:

The typical connections are shown by the scheme below. Number, colour as well as position of diodes in a specific model may vary. For flying at night it is useful to keep certain rules to make sure the model is visible in all positions and that night flying is safe. Unlike bulbs, ultra bright LEDs are narrow directional light sources. They light with angles 15, 23, and 30, rarely 70° and 120°. The directional characteristics of diodes should be adjusted so that they are visible from large angles. The easiest way to do that is by roughening them with emery paper. It is also possible to drop some adhesive from a fuse pistol on the diode, or combine these two methods. If the wing has a thick profile it is preferred to put two diodes there, one on the leading edge and the second on the trailing edge of the wing.

You may check function of the unit before installation by connecting it to the accumulator and touching light circuit outputs with diodes. In this way it is also possible to check the diode's colour as well. If you inverse the input voltage, there is neither danger for the unit nor for the diodes.

ATTENTION : Do not test the diodes by connecting them directly to the accumulator. Without using a compensating resistance you would destroy the diodes. Do not connect diodes to an output with a higher current than the nominal current of the diodes; they would be damaged. Diodes of 20mA can never be connected to an output of the headlight Land2. However, the other way round is possible.

When connecting the diodes you have to observe the polarity. The positive pole of 20 mA LEDs has a longer outlet (**a**) and the negative pole has a trimmed edge (**b**) and usually extends inside the body (**c**) to hold the chip. The type of construction and marking of diodes for the current of 150 or 350mA may vary. See appendix.

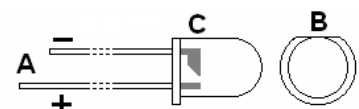

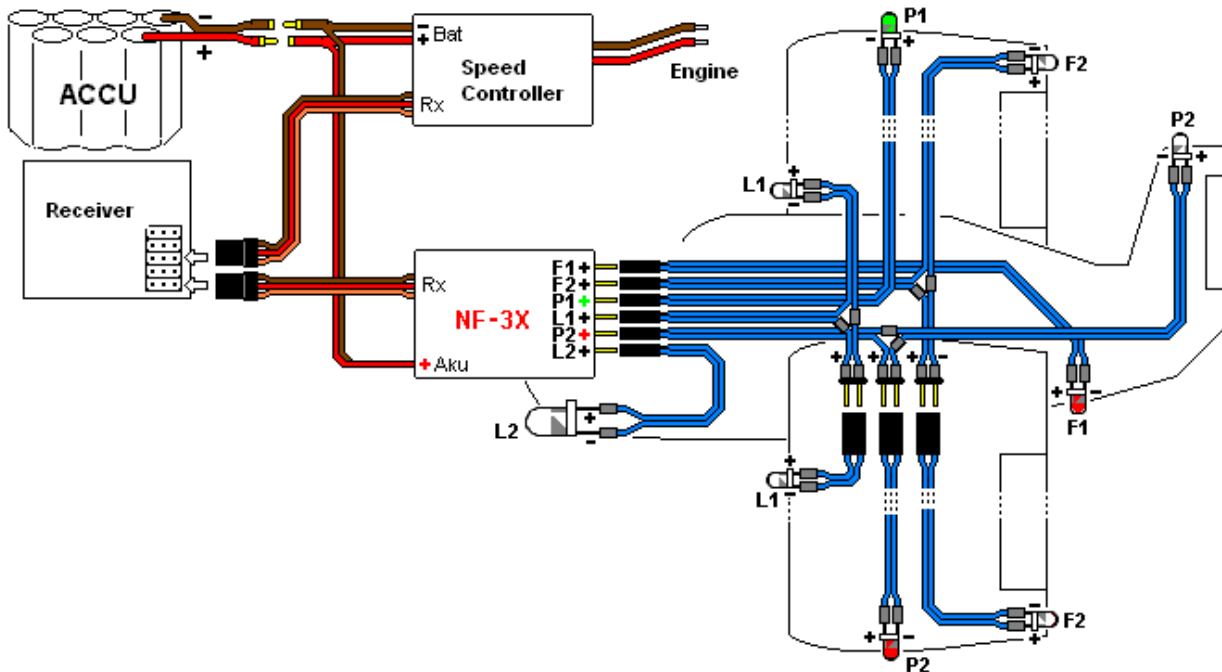

A short-term short circuit at a unit output does not harm the circuit thanks to the current outlets. The circuit regulates the current by burning the voltage difference between the supply voltage and the necessary voltage for diodes in the transistor. The worst condition for the unit is the case when the circuit is supplied by high voltage and short circuit at the output occurs. In that moment, the entire power (the passing current x power supply voltage) changes to heat in the transistor. The maximum operational voltage of 14V stated in the parameters is in accordance with that (12V transistor + approx. 2V diode).

With using seven-cell-accumulator, as in the schema, 2 green or 2 white diodes or 3 red or 3 yellow diodes can be connected serially into one output. It's only necessary to assume that the summa of voltages of diods plus 1,8V for output circuit functionality is below the voltage of accumulator, otherwise the luminosity od LEDs falls down. The typical working voltage for red and yellow LEDs is 1,8V. For white, green and blue it is 3,3V. The colors of diodes in one circuit can be combined. By models with on-board power supply of 6V and less there will probably not be possible to connect more than one diode to each output if you do not use a separate supply with a higher voltage for the light supply. Before starting with the installation, make an approximate calculation of the voltage output summa. Accumulator voltage must be higher than the highest summa of nominal diode voltage in outputs plus 1,8 volts (minimum for electronic circuits).

The unit heats to much if the accumulator voltage is too much higher than necessary. Just for guidance, you can connect the unit in your expected configuration and check the temperature of coolers by touching them occasionally; holding it for longer you would carry the heat off to your fingers. If you can still keep your fingers on the cooler after two or three minutes, everything is ok. Be careful; diodes, especially with current 350mA heat up a lot. It is not recommended to close them in polystyrene as they need some air circulation around. Superheating causes loss of brightness and subsequent damage of the diode.

The unit can be fixed by screw of the cooler clamps in the way you unscrew the nuts and replace them by distance columns that are part of the accessories. Column with inside thread or column with external thread can be used as you need. The distance columns can be screwed or glued to the plywood into pre-grinded hole. The space around the unit should be considered too as to the air circulation and especially the access to the connectors and jumpers if your model is demountable one. It is not recommended to close the unit in polystyrene as they need some air circulation around.

The total average current consumption is about 70 mA on "Fly" mode in case of seven-cell supply. During 10 minutes of fly the light circuits burn only a little bit more than 1 % of capacity of a 700 mAh accumulator.

Making the cabling:

Connection of diodes to unit can be fixed by soldering wires directly to the unit contacts or demountable by using connectors. Whether you use any pair-cable or enamel, it is necessary to prepare cables with a sufficient reserve. A few centimetres in excess can always be hidden but just one missing centimetre will cause a big trouble. Before connecting the diodes remove the insulation from 5mm of the cable and tin the diode and the cable. This will shorten time needed for soldering. If you intend to put thermo-shrinkable insulation tube over the connection, prepare 9mm-long pieces of insulation. They shall be pulled on

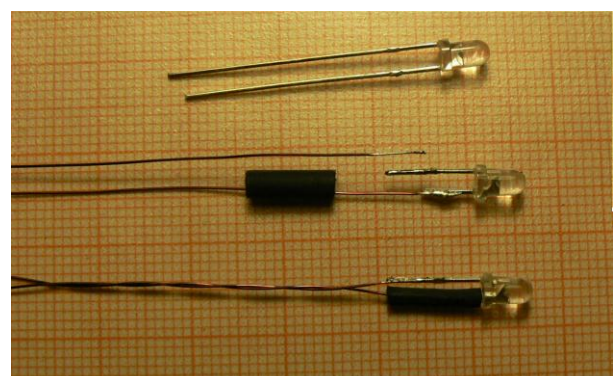

the wire beforehand as far as possible from the intended soldered connection – if you don't do so, they might shrink in a wrong place. After soldering in both stems and cooling pull the insulation on the connection and heat it gently from all sides with the solder so that it would shrink (you need to try it). It is recommended to heat at a place behind the tip where the solder is clean. Thus the insulation will not be littered with tin and resin.

After fixing the diodes and checking the length of cables connectors have to be connected. They could be crimped without soldering but once you have the solder in your hand or do not have the tools for crimping, I would recommend soldering. Divide the couple of wires for about 20-25mm and remove about 4mm of the insulation of wire and tin it. If you are not fast, the insulation will recede a little more. Shorten the un-insulated tinned wires to 2-3mm. Break off two sockets and gently clamp them parallel in a clamp at a distance at which they will be in the connector. The included fork adaptor can be used for clamping as well. Ideally you fix the sockets and the wire on a surface area.

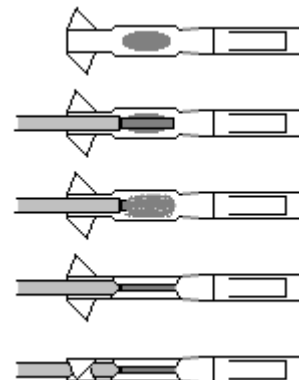

Drop a little tin in the middle part of the socket, not too much. The thin tube tin is easier to dose. Put the wire in the farther socket and heat it so that the tin connects. Then repeat it with the closer socket. See to it that the wire and the socket would be in line. If your hand slips, you can heat the wire again and when it gets released, fix it. Keep eye on the solder temperature, you might lose the insulation. Keep the same polarity with all the cables, it is aesthetical.

Bend the borders of the channels round with flat pliers. Then bend the plates around the insulation and finally put the sockets into the connector so that the locks would lock on and cannot be pulled out again. If there is resistance, gently try to lift the lock on the connector with a tip. Not too much, otherwise it will stay open forever. Lean the tip at the edge of the socket and gently move it forward. You probably used too much tin or bent the borders too little.

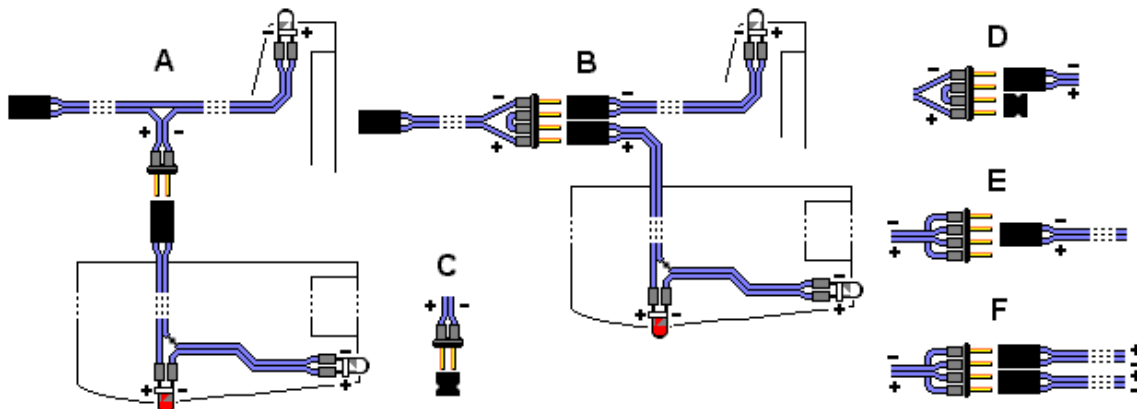

Pre-flight tests:

- 1) The temperature conditions on the landing light cooler as well as on the landing diode (or diodes) has to be checked, especially in case of a current of 350mA and more.
- 2) Interference test - The diode wiring is not a source of interference. However, it might distribute interference through the entire model from an insufficiently shielded engine. Therefore, it is not recommended to lay them concurrently with the receiver antenna as they could affect the reception. Thus it can happen that a model that used to fly without problems starts plucking after installation of lights (e.g. by certain revolutions). After installation it is better to check the model's behaviour on the ground first and improve shielding if necessary or (in especially severe cases) to put a suppression component before the illumination unit supply. A separate supply for the model illumination can be used too .

Have a nice fly.

Technical parameters:	min.	typ.	max.
Input voltage :	5V	9V	14V
Consumption (unit):	18mA	20mA	25mA
Temperature		0 - 70°C	
Dimensions:	74 x 52 x 13 (19)mm *		
Weight:	35.0g	37.0g	41.5g *

* according to power of L2

Production
 Ivan Pavelka
 K Roztokům 65
 165 00 Praha 6 – Suchbát
 Czech Republic
<http://www.nightfly.cz>
i.pavelka@volny.cz
 tel.: +420 605 404 499
 fax.: +420 220 921 744

Distribution. :

Appendix : LED Polarity Mark

For 20 and 80 mA diodes the positive pole has a longer outlet (**a**) and the negative pole has a trimmed edge (**b**) and usually extends inside the body (**c**) to hold the chip.

ParaLight type LEDs 150mA have a "dot mark" near the negative pole (cathode). The positive pole is often in the opposite corner. ATTENTION : Red LEDs have cathode in the middle contact.

